

crydom[®]

DP Series Solid State Contactors



The Global Expert in **Solid State Relay** Technology

A brand of
CST
CUSTOM SENSORS & TECHNOLOGIES

ABOUT US

Crydom, a brand of Custom Sensors & Technologies (CST) and **global expert in Solid State Relay Technology**, has a distinguished record of providing high quality, world class Solid State Relay and Control Products for a variety of heating, lighting and motion control applications. Crydom products, coupled with **unparalleled technical support, timely delivery and competitive pricing**, provide Crydom's clients with the innovative products and support necessary to succeed in today's competitive and fast paced global markets.

Crydom's extensive selection of standard off-the-shelf products is constantly being updated and expanded through its continuous improvement and aggressive new product development programs. Utilizing state of the art designs, materials and technology, Crydom offers a wide range of AC and DC output SSRs in industry standard Panel Mount, PCB Mount and DIN Rail packages, all **meeting global safety and standards agency requirements** such as CE, RoHS, UL, IEC, etc.

Bolstered by four decades of Solid State Relay operations experience, Crydom also specializes and encourages **adapted and fully custom-designed SSR products** for nearly any application where unique specifications and optimized performance are critical for success.

Crydom's modern purpose-built **100,000 square foot manufacturing facility** houses all aspects of its ISO certified operation including Design and Development Engineering, Manufacturing Operations and Quality Assurance, Customer Service, Finance, Marketing and General Management, permitting close coordination of all aspects of Crydom's activities. Applications Engineering and Sales support are both performed in the field to provide Crydom's Customers with the unparalleled technical and commercial support.

Following rigid design guidelines and standards, Crydom products have set the bench mark for SSR performance and reliability world wide. In addition to **award winning designs**, Crydom has acquired an impressive list of **patents** related to SSRs and Solid State Controls, while continuing to develop new circuit and technology-related inventions as part of **extensive R&D programs**.

To learn more about Crydom SSR technology and products, or how an alliance with Crydom can contribute to the success of your project, visit **www.crydom.com** or contact your authorized Crydom Distributor or Crydom Customer Service Representative today.

DP SERIES SOLID STATE CONTACTORS

Panel Mounted DC Load Reversing Solid State Contactors

The **DP Series** of DC Load Reversing Solid State Contactors (SSCs) include four optically isolated DC low dissipation FET outputs rated up to 60 amps at 48 VDC, wired in an H-Bridge configuration with a common input control to provide a convenient method to both power on and off and reverse the polarity to a variety of DC loads including motors, brakes, clutches, electro magnets, solenoids, plating baths and electrolytic cells. The **DP Series** is housed in a compact encapsulated industry standard 75 x 105 mm panel mount package featuring screw termination for power and load connections and a 4 conductor connector for control connections.

Flexible Control of DC Load

In addition to the on/off and reversing functions, **DP Series** Contactors include an internal interlock circuit to prevent damage due to overlapping forward/reverse control commands. The **DP Series** also offers options for a variety of combinations of Internal PWM Soft Start/Ramp Up, PWM Soft Stop/Ramp Down and Dynamic Brake functions. Available with a selection of set ramp times, the soft start and stop functions provide a convenient means to eliminate or reduce the mechanical shocks associated with starting and stopping DC electro-mechanical loads.

Ratings & Approvals

The **DP Series** of Solid State Contactors are available with either 20, 40 or 60 Amp general use ratings in a 40°C ambient temperature with appropriate heat sinking. The output will switch from 1 to 48 VDC. Available control inputs are conveniently matched to the input logic supply to accept either 4.5 to 15 VDC or 18 to 32 VDC from a common power supply. **DP Series** SSCs are CE Certified, RoHS Compliant, UL/cUL Recognized and carry Motor Control Ratings up to 15 FLA at 48 VDC.

For additional information about the **DP Series** DC Reversers, including available thermal management accessories, contact the nearest Crydom Distributor, Representative or local Crydom Sales Office, or visit our website at www.crydom.com.



DP Series DC Load Reversing Solid State Contactors

- Convenient FET switches in H-Bridge configuration
- Control features to combine Soft Start/Ramp Up, Soft Stop/Ramp Down & Braking functions on each polarity
- Built-in protective Forward/Reverse interlock function
- 20, 40 & 60 Amps Operational Current rating
- 48 VDC Rated Operating Voltage
- UL & IEC ratings for general use & Motor loads
- 4.5 to 15 VDC & 18 to 32 VDC Input Control Voltage options available
- LED Status indicators for Operating Modes
- Industry standard 75 x 105 mm Panel Mount package

| Output Specifications (A) | DP4Rxx60x20xx | DP4Rxx60x40xx | DP4Rxx60x60xx |
|--|---------------|---------------|---------------|
| Operating Voltage Range [VDC] (B) | 1-60 | 1-60 | 1-60 |
| Rated Operating Voltage [VDC] | 48 | 48 | 48 |
| Maximum Off-State Leakage Current @ Rated Voltage [µA] | 20 | 20 | 20 |
| Minimum Load Current [A] | 0.10 | 0.10 | 0.10 |
| Maximum Surge Current (10 ms) [ADC] (C) | 80 | 140 | 240 |
| Maximum On-State Resistance, per FET switch (RDS-ON) [Ohm] | 0.014 | 0.007 | 0.005 |
| Maximum On-State Voltage Drop @ Rated Current [VDC] | 0.28 | 0.28 | 0.3 |
| Total Power Dissipation per module, 2 FET switches conducting, Tj=100° C [Watts] | 20 | 40 | 60 |
| Combined Thermal Resistance Junction to Case (Rjc) [°C/W] | 0.4 | 0.2 | 0.13 |
| Internal PWM For Soft Start/Stop Versions (Duty Cycle 10-100%) [Hz] | 200 | 200 | 200 |
| UL 508 General Use Load Current @ Rated Voltage [A] (D) | 20 | 40 | 60 |
| UL 508 Motor Controller Load Current @ Rated Voltage [FLA] (D) | 13 | 14 | 15 |
| IEC 60947-4-1 DC-1 Load Current @ Rated Voltage [ADC] (D) | 20 | 40 | 60 |
| IEC 60947-4-1 DC-3 Load Current @ Rated Voltage [FLA] (D) | 13 | 14 | 15 |

| Input Specifications (A) | DP4Rxx60D40xx | DP4Rxx60E40xx |
|---|---------------|---------------|
| Logic Supply Voltage Range (pin 5) [VDC] | 4.5 - 15 | 18 - 32 |
| Min/Max Logic Supply Current (pin 5) [mA] (E) | 16/20 | 20/25 |
| Control Voltage Range (pin 7, pin 8) [VDC] | 4.5 - 15 | 18 - 32 |
| Minimum Control Input Current @ Min voltage (pin 7, pin 8) [mA] | 0.20 | 1 |
| Maximum Control Input Current @ Max voltage (pin 7, pin 8) [mA] | 1 | 2 |
| Typical Interlocking Time [msec] | 200 | 200 |

| General Specifications (A) | DP4Rxx60x20xx | DP4Rxx60x40xx | DP4Rxx60x60xx |
|---|------------------------------------|---|------------------------------------|
| Dielectric Strength, Input-Output to Baseplate (50/60Hz) [Vrms] | | 2500 | |
| Minimum Insulation Resistance @ 500 VDC [Ohm] | | 10 ⁹ | |
| Maximum Capacitance, Input to Output [pF] | | 28 | |
| Ambient Operating Temperature Range [°C] | | -30 to 80 | |
| Ambient Storage Temperature Range [°C] | | -40 to 125 | |
| Housing Material (Shell) | | Black, UL 94 V-0 | |
| Encapsulation | | Thermally conductive Epoxy | |
| Weight (typical) [oz] (gr) | 10.93 (310) | 12.16 (345) | |
| Input Locking Connector | | Rectangular Header, Male Pin 4 Positions, 0.100 in [2.54] Pitch (F) | |
| Output Terminals | Screw / Clamp Combo Type 10-32 | Hex Screw Type 1/4-20 with lock washers | |
| Maximum Torque [in-lbs] (Nm) | 20 (2.2597) | 25 (2.8246) | |
| Input Connector Wire Capacity | | AWG #24 (0.2 mm ²) | |
| Wire Size for Maximum Ratings (with terminals) | AWG #12 (IEC 3.3 mm ²) | AWG #8 (8.4 mm ²) | AWG #6 (IEC 13.3 mm ²) |
| IP rating | | IP00 | |
| LED Status Indicator | | Green LED (Forward), Yellow LED (Reverse). See TABLE 2 | |
| IEC 60068-2-6 : Vibration | | Compliant (1.5 mm / 10-55 Hz) | |
| IEC 60068-2-27 : Shock | | Compliant (15 G / 11 ms) | |
| IEC 61000-4-2 : Electrostatic Discharge | | Level 2 | |
| IEC 61000-4-4 : Electrically Fast Transients | | Level 2 - Criteria A | |
| IEC 61000-4-5 : Electrical Surges | | Level 2 - Criteria B | |

General Notes

- (A) All parameters at 25°C unless otherwise specified.
- (B) Soft Start and/or Soft Stop options are not available when the DC supply voltage is less than 7 VDC.
- (C) Maximum Surge Current rating not to be exceeded during motor Starting or Dynamic Braking.
- (D) For maximum ratings use heat sink ratings in TABLE 1.
- (E) Input circuit incorporates active current limitation.
- (F) Suggested mating connector/plug : Crimp Housing, Positive Latch (Molex 050579404).



To view available Installation Sheet scan the QR code with your smartphone or visit www.crydom.com

Derating Curves (D)

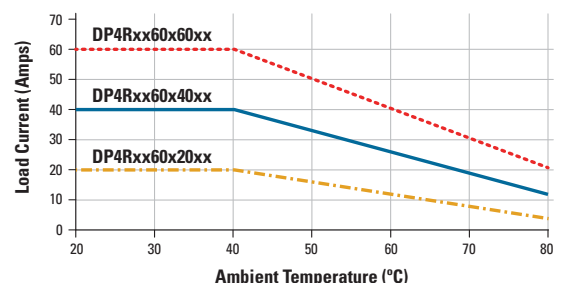

Part Number Nomenclature (G)

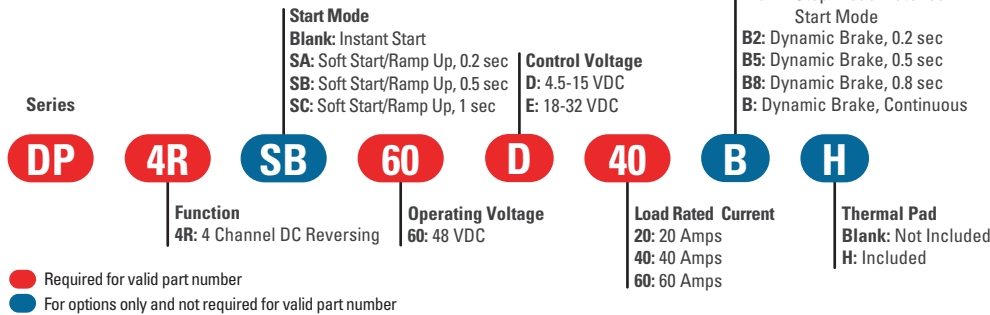

| DP Series Part No. | Required Heat Sink [°C/W] | Crydom Heat Sink Part No. |
|--------------------|---------------------------|---------------------------|
| DP4Rxx60x20xx | 1.5 | HS103 / HS103DR |
| DP4Rxx60x40xx | 1.0 | HS103 / HS103DR |
| DP4Rxx60x60xx | 0.5 | HS053 |

Mechanical Dimensions (H)

Tolerances: ±0.02 in / 0.5 mm
All dimensions are in: inches [millimeters]

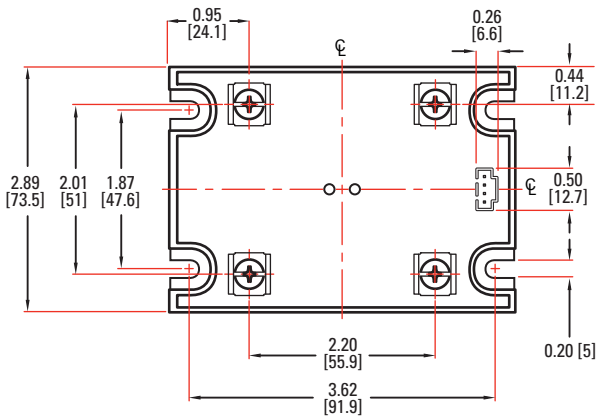

DP4Rxxxxx20

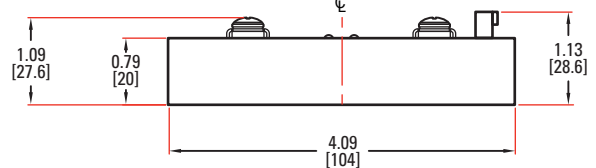

DP4Rxxxxx40 & DP4Rxxxxx60

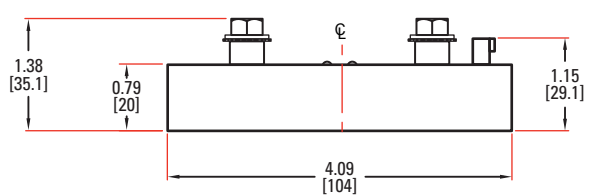

Wiring Diagram

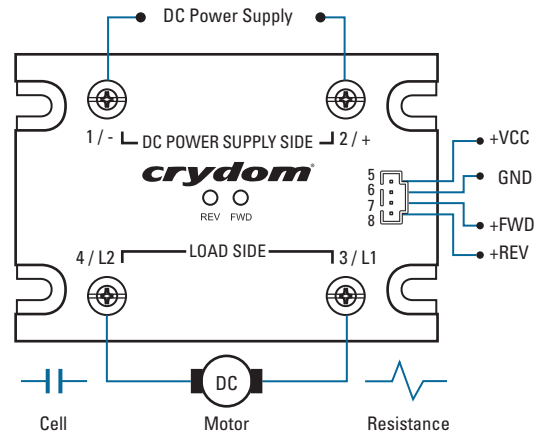

Block Diagram

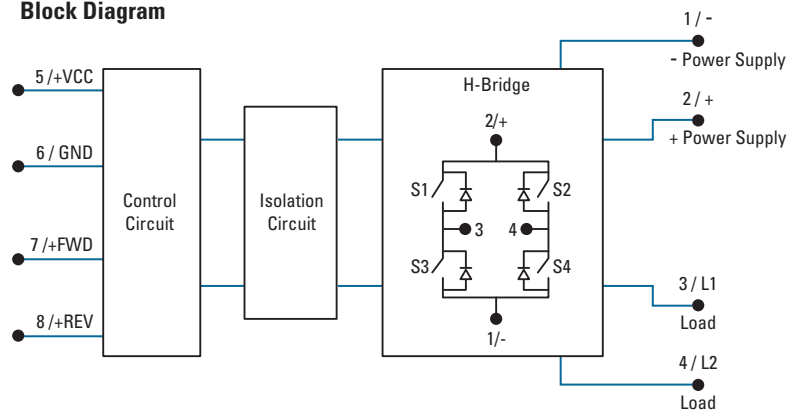

TABLE 2

| Status Functions | Green LED (Forward) | Yellow LED (Reverse) |
|---------------------------------|-------------------------|-------------------------|
| Initial Logic Supply Voltage On | Flash Twice | Flash Twice |
| Forward ON | ON | OFF |
| Reverse ON | OFF | ON |
| Dynamic Brake | Flash Once | Flash Once |
| Interlocking | Flash 3x Intermittently | Flash 3x Intermittently |

TABLE 3

| DP Series Part No. | Accessories | | | | | |
|--------------------|-------------|-------|---------------|-------------|------|------|
| | HK1 | HS053 | HS103 HS103DR | HSP-3 HSP-5 | TRM1 | TRM6 |
| DP4Rxx60x20xx | ◆ | | ◆ | ◆ | | ◆ |
| DP4Rxx60x40xx | ◆ | | ◆ | ◆ | ◆ | |
| DP4Rxx60x60xx | ◆ | ◆ | | ◆ | ◆ | |

(G) For a complete description of available Operating Modes, see definitions on page 5.
(H) Baseplate Thickness 0.125 [3.2]

Operating Modes

Start: When either FWD or REV Control signal is applied, and after Control Signal Validation Delay, DC power supply on terminals 1/- and 2/+ is directly connected to Load at terminals 3/L1 and 4/L2 with a polarity according to the control signal. The start option can be combined with Stop and/or Dynamic Brake options.

Stop: Load is disconnected from DC power supply. All FET switches (S1, S2, S3 & S4) inside the DP Series SSC are turned off. This simple Stop option is available only in combination with the simple Start option (suffix Blank).

Soft Start/Ramp Up: It is a modified Start where the DC power supply is connected to the load using a 200 Hz pulse width modulation with a duty cycle going from 10% to 100%. Soft Start/Ramp Up time is defined by SA, SB and SC suffixes. After Soft Start/Ramp Up time is elapsed, the Load will remain continuously energized for as long as FWD or REV Control signal is applied. This option can be combined with Soft Stop/Ramp Down and Dynamic Braking modes, but not with simple Stop.

Soft Stop/Ramp Down: It is a modified Stop where the DC power supply is disconnected from the Load

using a 200 Hz pulse width modulation with a duty cycle going from 100% to 0%. After Soft Stop/Ramp Down time is elapsed, the Load will remain continuously de-energized waiting for a new FWD or REV Control signal. Soft Stop/Ramp Down time is tied to Soft Start/Ramp Up time selected by SA, SB and SC suffixes and can be combined with Soft Start/Ramp Up only.

Dynamic Brake: It could be used as a modified Stop where the FET switches inside the DP Series SSC are arranged in such a way that they provide a path for the Load Current to keep flowing after the DC power supply has been disconnected. This mode allows for energy stored in some type of loads to be discharged. i.e. back EMF on DC motors. Timing for Dynamic Brake is selected by suffixes B2, B5, B8 and B where the latest will keep the braking or discharging path enabled for as long as FWD and REV Control signals are removed.

Interlock: It will shut down all FET switches inside the DP Series SSC within 0.2 sec after both control signals FWD and REV are applied at the same time. An Interlock condition will trigger a modified Stop such as Soft Stop/Ramp Down or Dynamic Brake whenever an option has been selected.

Control Signals

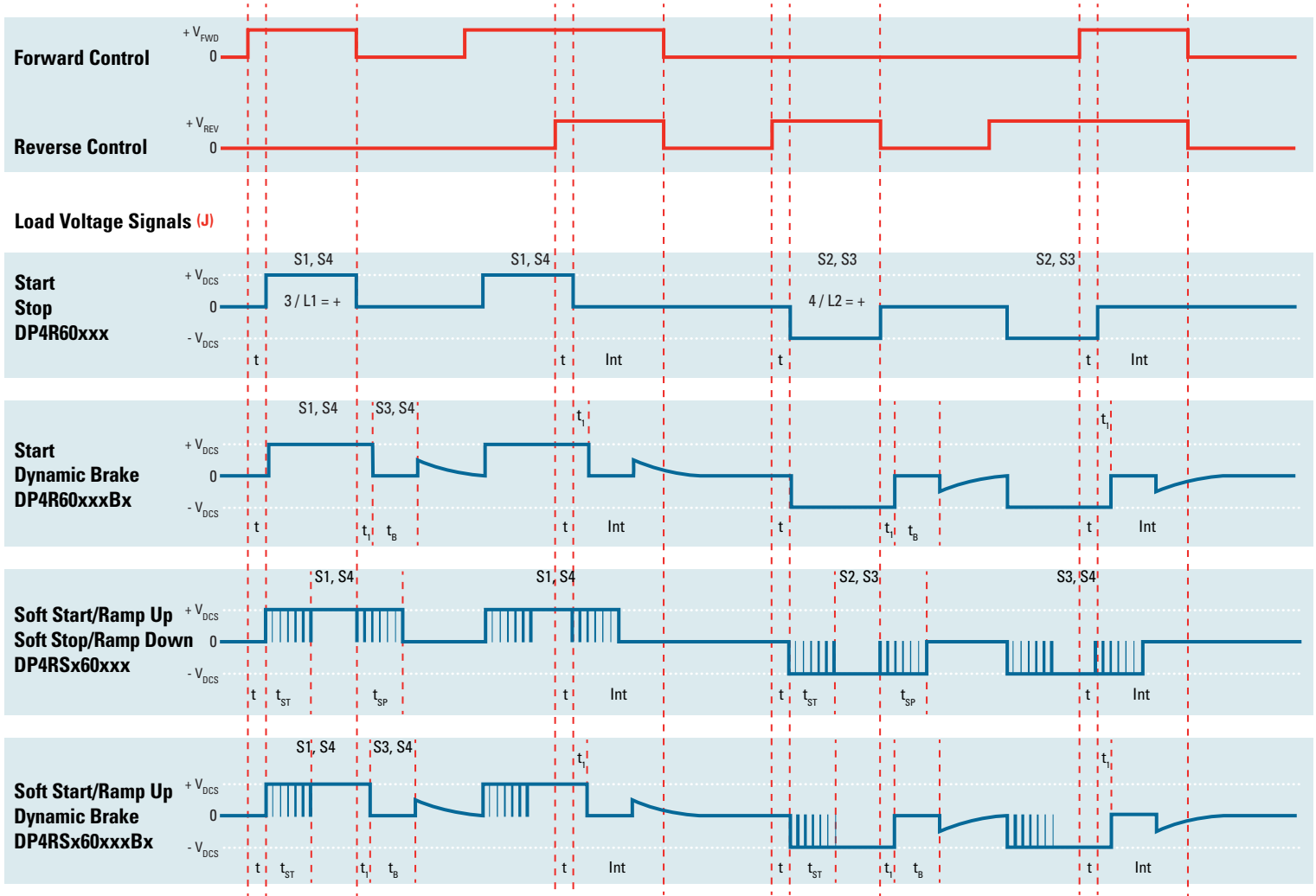

Int : Interlock

t : Control Signal Validation Delay = 0.2 sec, except for Start / Stop (0.025 sec)

t_i : 0.15 sec Break-before-make delay

t_B : Dynamic Brake time

B2: 0.2 sec

B5: 0.5 sec

B8: 0.8 sec

B: Continuous

t_{sp} : Soft Stop/Ramp Down time = t_{st}

t_{st} : Soft Start/Ramp Up time

SA: 0.2 sec

SB: 0.5 sec

SC: 1 sec

V_{DCS} : VDC power supply

V_{FWD} : Forward Control Signal

V_{REV} : Reverse Control Signal

(J) Load voltage signals shown are typical of a DC motor, behavior may change for other load types.

crydom®

AMERICA



United States & Canada

Crydom Inc
2320 Paseo de las Americas,
Suite 201
San Diego, CA 92154

Sales Support:
Tel.: +1 (877) 502 5500
Fax: +1 (619) 210 1590
sales@crydom.com

Technical Support:
Tel.: +1 (877) 702 7700
support@crydom.com

Mexico

**Automatismo Crouzet
S.A. de C.V.**
Calzada Zavaleta 2505-C Col
Sta Cruz Buenavista C.P.
72150 - Puebla

Sales Support:
Toll free: 01 800 087 6333
Tel.: +52 (222) 409 7000
Fax: +52 (222) 409 7810
sales-mx@crydom.com

Technical Support:
Toll free: 01 800 838 3736

Southern & Central American Countries CST Latinoamerica

Alameda Rio Negro, 1030,
18º andar – Conjunto 1803
CEP: 06454-000
Barueri - São Paulo
Brasil
Tel.: +55 (11) 2505 7500
Fax: +55 (11) 2505 7507
info@cst-latinoamerica.com

EUROPE, MIDDLE EAST & AFRICA



United Kingdom

Crydom SSR Ltd
Arena Business Centre
Holyrood, Close
Poole, Dorset BH17 7FJ

Sales Support
Tel.: +44 (0) 1202 606030
Fax: +44 (0) 1202 606035
sales-europe@crydom.com

Tech Support
support-europe@crydom.com

Austria & Switzerland

Tel.: +44 (0) 1202 606030
Fax: +44 (0) 1202 606035
vertrieb@crydom.com

Belgium

Tel.: +32 (0) 2 460 4413
Fax: +32 (0) 2 461 2614
sales-europe@crydom.com

France

Tel.: +33 (0) 810 123 963
Fax: +33 (0) 810 057 605
sales-europe@crydom.com

Germany

Tel.: +49 (0) 180 3000 506
Fax: +49 (0) 180 3205 227
vertrieb@crydom.com

Italy

Tel.: +39 (0) 2 665 99 260
Fax: +39 (0) 2 665 99 268
sales-europe@crydom.com

Spain

Tel.: +34 902 876 217
Fax: +34 902 876 219
sales-europe@crydom.com

Netherlands

Tel.: +31 (0) 71 582 0068
Fax: +31 (0) 71 542 1648
sales-europe@crydom.com

Middle East, Africa & Other European Countries

Tel.: +44 (0) 1202 606030
Fax: +44 (0) 1202 606035
sales-europe@crydom.com

ASIA PACIFIC



China & Hong Kong

**Custom Sensors &
Technologies Asia
(Shanghai) Ltd.**
13th floor
Chang Feng International
Tower
89 Yunling Road (East)
Putuo District
Shanghai, 200062

Sales Support
Tel.: +86 (0) 21 6065 6699
Fax: +86 (0) 21 6065 7749
sales-cn@crydom.com

Tech Support
support-cn@crydom.com

Taiwan & Japan

**Custom Sensors &
Technologies**
2F, No. 39, Ji-Hu Road
Nei-Hu Dist.
Taipei 114
Tel: +886 2 8751 6388
Fax: +886 2 2657 8725
taiwan@cstsensors.com

South Korea Custom Sensors & Technologies

2F, Jeil Bldg.,
94-46 Youngdeungpo-dong
7-ga Youngdeungpo-gu,
Seoul, 150-037
Tel.: +82 2 2629 8312
Fax: +82 2 2629 8310
korea@cstsensors.com

India

CST Sensors India Pvt Ltd
4th Floor, Trident Towers,
No. 23, 100 Ft- Ashoka Pillar Road,
2nd Block, Jayanagar,
Bangalore- 560011
Tel: +91 (80) 4113 2204 /05
Fax: +91 (80) 4113 2206
india@cstsensors.com

South East Asian & Pacific Countries Custom Sensors & Technologies

2F, No. 39, Ji-Hu Road
Nei-Hu Dist.
Taipei 114, Taiwan
Tel.: +886 2 8751 6388
Fax: +886 2 2657 8725
eap@cstsensors.com

© 2011 Crydom Inc., All Rights Reserved.

Specifications are subject to change without prior notice.
Crydom and the Crydom logo are registered trademarks
of Crydom Inc.

06/2011

CAT/CR/DP/EN

Distributed by :

